

Alfa Numeric 16 Digits Vacuum Fluorescent Displays

Widely used displays in AWP machines from most British and Dutch manufacturers.

Two different connector types available:

Black 9 pin + slot box connector: Samsung part number 16LF01UA4 rev c

White 5 pin + slot edge connector: Samsung part number 16LF01UA4S rev c

Features:

- Display size (WxH) 173.6 x 14.25 mm (Overall size 218 x 45 mm)
- Character size (WxH) 7.0 x 12.50 mm
- Display colour: Blue Green (Peak 505nm)
- Simple connection to the host machine via two wire serial interface.
- Because of the use of DC/DC converter, only +12Vdc is required to operate. (max15Vdc)
- Supply current 300-400 mA.
- One chip offers integral 64x16 bit programmable logic array.

For more technical specs, please contact our sales team.

Part no.	Description
16LF01UA4	Samsung A/N display straight double row 2x6 pins connector black
16LF01UA4S	Samsung A/N display pin header 6 pins friction lock white



Dot Matrix 16 Digits Vacuum Fluorescent Display

Widely used displays in AWP machines from most British and Dutch manufacturers.

Black 9 pin + slot box connector: Samsung part number 16L102DA4 rev d.

Features:

- Display size (WxH) 173.2 x 13.55 mm (Overall size 218 x 45 mm)
- Digit format: 5 x 7 Dot Matrix with Comma & Decimal points
- Character size (WxH) 6.76 x 12.50 mm
- Display colour: Blue Green (Peak 505nm)
- Host machine can control this module by four signals, chip select(/SEL), shift clock(SCLK), Serial data (SDATA) and reset(/RSET)
- Because of the use of DC/DC converter, only +12Vdc is required to operate. (max.15Vdc)
- Supply current 300-400 mA.
- The unit has up to 8 user definable characters (CG-RAM function)

For more technical specs, please contact our sales team.

Part no.	Description
16L102DA4	Samsung D/M display 16 digits



1DU Dice Unit

A tumbling dice with true-to-life 3-dimensional dice action.

Can be used as a feature or central game device, controlled tumbling in free space appears real to the player.

- Customer specified decals (dots, shapes, animals etc).
- Modular construction with Quick Release Feet and a variable mounting angle make the unit simple to incorporate.
- 48 step, 12V motor for simple electrical interfacing.
- The dice is available in multiple colours for maximum flexibility in game design.

Part no.	Description
22-2135-XX	1DU dice unit



1FD Flexi Disc

The 1FD Flexi Disc is a feature mechanism with a disc of 340mm diameter, bent through 90° taking up only 160mm radius of glass space.

- Unique design allows this mechanism to be used in confined spaces or combined with other game devices in closed proximity.
- Illumination of up to 7 individual symbols using 12 independent lamps connected in a 4x3 matrix.
- Disc can be configured with either 12 or 16 symbols allowing flexibility in game design.
- Simple fitting of a game specific printed disc.
- Proven reliability with over 10.000 units in operation.
- 48 step 12V motor for easy interface to host machine.

*** Please specify build ***

Part no.	Description
22-2150-XX	1FD flexi disc

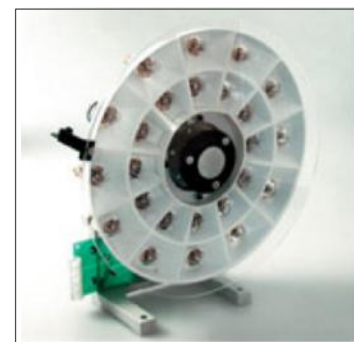

1DM Disc Mechanism

A modular disc mechanism mounted on a standard reel mechanism frame.

The flat disc allows any variation of symbols to be used, complete with rear illumination of multiple symbols.

- An user-definable disc allows precise adaptation to machine design.
- Flat symbol presentation offers an alternative to the standard reel unit.
- 12V or 24V stepper motor provides simple interfacing.
- Illumination with lampholders mounted on vacuum formings allows incorporation with specific game design.

*** Please specify build ***

Part no.	Description
22-2148-XX	1DM disc mechanism
22-2151-XX	2DM disc mechanism



19RM Reel Mechanism

Compact reel mechanism for use in confined spaces.

- 150mm diameter, 66mm wide reel drum allows design into bartop machines or confined spaces in standard machines.
- Unique combined 'Handle in Latch' fitting system, connects both mechanically and electrically in one action.
- Handle provides convenient carrying point for easy handling in production.
- 3 lamp illumination moveable through 360°.
- Individual mounting foot incorporating host machine connector.
- 48 step and 100 step motor options.

Part no.	Description
22-2146-XX	Reel mechanism 19RM

For ordering or re-ordering reel mechanisms or game devices, please ask for special order form or alternatively mention project number as printed on product sticker.



20 and 21RM Reel Mechanism

- Unique combined "Handle and Latch" fitting system which connects both mechanically and electrically in one action
- Host connector locates in the mounting base
- Illumination moveable through 360° allowing mounting in any position
- Handle provides convenient carrying point for easy handling in production
- Based on proven Starpoint 16RM/17RM technology with full range of drums and motors

Part no.	Description
22-2145-XX	Reel mechanism 20RM
22-2141-XX	Reel mechanism 21RM



12RM Reel Mechanism

Traditional reel mechanism with the widest range of motor options and machine interfaces.

- Simple, rigid plastic frame.
- A traditional reel drum for quick, simple fitting of reel bands.
- A wide range of drum widths (56mm-90mm) to suit all designs.
- Quick release feet for simple mounting without the need for tools.
- Interface boards to suit all requirements across the widest range of applications.
- Calibrated reel tape positioning.
- 3 and 6 lamp - 180° adjustment illumination array.
- RMS (Reel Movement Sensing) option available.

Part no.	Description
22-2128-XX	Reel mechanism 12RM



17RM Reel Mechanism

Low cost reel mechanism with traditional reel drum.

- Simple, rigid plastic frame.
- A traditional reel drum for quick, simple fitting of reel bands.
- A wide range of drum widths (56mm-90mm) to suit all designs.
- Quick release feet for simple mounting without the need for tools.
- Integrated moulding with motor, position detection and illumination mean win line position are easy to adjust, with no complicated set-up.
- 48 step or 100 step motor to meet the widest range of applications.
- 3 and 6 lamp - 180° adjustment illumination array.

Part no.	Description
22-2129-XX	Reel mechanism 17RM

Modular reel mechanism options



	21RM	20RM	19RM	17RM	16RM	12RM
Frame type	PLASTIC with handle mechanism	PLASTIC with handle mechanism	PLASTIC with handle mechanism	PLASTIC rigid frame	PLASTIC rigid frame	PLASTIC lattice frame
Reel drum type	Double or Single sided	Double or Single sided	Double Sided	Double Sided	Single Sided	Double Sided
Reel drum 230mmø						
Width 56mm						
Width 66mm	∨	∨		∨	∨	∨
Width 79mm	∨	∨				
Width 90mm	∨	∨				
Width 100mm					∨	
Reel drum 210mmø						
Width 56mm	∨	∨		∨		
Reel drum 150mmø						
Width 66mm	∨	∨	∨			
Stepper motor options						
48 step	∨	∨	∨	∨	∨	∨
100 step	∨	∨	∨	∨	∨	∨
200 step						∨
Electrical Interface	Flying lead connector	Connectors incorporated in frame and base	Connectors incorporated in frame and base	Standard	Standard	Many options
Mechanical fitting	Modular base or individual foot with 'Handle & latch' system	Modular base or individual foot with 'Handle & latch' system	Individual mounting foot with 'Handle & latch' system	Fixing feet	Fixing feet	Fixing feet
Reel movement sensing						∨

Reel Mechanisms



Reel Drums

Used in most AWP games.

Part no.	Description
22-2116-1	C1005-H 8 Spoke 79.5mm wide
22-2116-2	C744-H 8 Spoke 66.0mm wide
22-2116-4	C1008-H 8 Spoke 90.0mm wide



Reel Unit Motor NMB

Part no.	Description
22-2133	24V. 48 step NMB motor
22-2133-3	12V. 200 step NMB motor used on 12RM and 18RM
22-2133-1	12V. 48 step NMB motor



Opto Sensor

For 17RM/20RM/FM3 reel units.

Part no.	Description
22-2112-1	For reel unit wide B520



Quick-Release Foot

Starpoint ref: A174 for use on 12RM, 16RM and 17RM.

Part no.	Description
22-2123-1	Quick-release foot



Front Mounting Foot

Starpoint ref: B788 for use on 12RM, 16RM and 17RM.

Part no.	Description
22-2123-7	Foot



Opto Tab

- A is Starpoint ref: A1695 for 12RM.
- B is Starpoint ref: B583 for 7RM/11RM.

Part no.	Description
22-2117	Opto tab A1695
22-2115	Opto tab B583



Reel Unit Clip

Starpoint ref: A1274.

Part no.	Description
22-2123	Reel unit clip



Opto Tab

For use on reel units 17RM and 18RM.

Part no.	Starpoint no.	Description
22-2120	For	66.0mm wide reel
22-2120-1	A2398 for	79.5mm wide reel
22-2120-2	A2404 for	90.0mm wide reel



Lamp Holder Tool

Lamp holder tool, to fit wires in 22-2162 lamp holders.

Part no.	Description
22-2161	Lamp holder tool



IDC Insertion Tool

Insertion tool for Advanced Technology connectors.

Part no.	Description
22-2161-1	Insertion tool



IDC Extraction Tool

Extraction tool for Advanced Technology connectors.

Part no.	Description
22-2161-3	Extraction tool



Modulare Mounting Base RM20

Starpoint ref: 40066

Part no.	Description
22-2122	Modulare mounting base RM20 40066



Modulare End Base RM20

Starpoint ref: 40068

Part no.	Description
22-2122-1	Modulare end base RM20 40068

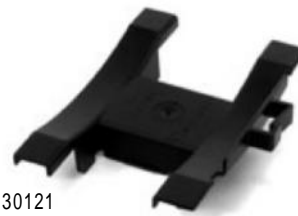

Cable Cover RM20

Starpoint ref: 30121

Part no.	Description
22-2122-5	Cable cover RM20 30121



Individual Foot RM20

Starpoint ref: 30063

Part no.	Description
22-2122-2	Individual foot RM20 30063



Individual Foot RM19

Starpoint ref: 40105

Part no.	Description
22-2190	Individual foot RM19 40105
22-2190-1	Cover individual foot RM19 20155

Pushbuttons



ILLUMINATED PUSHBUTTONS CLASSIC SERIES

- High quality materials.
- Microswitch included.
- Standard without lamp and/or artwork.
- Inscription labels available.
- Accommodate standard 10mm wedge base lamps.
- Sizes include black bezel.
- Fitting hole $\varnothing 24\text{mm}$.

All pushbuttons are available in the following colours:

Colour	Part no.
Red	2
Orange	3
Yellow	4
Green	5
Blue	6
White	9



Square Small Button

Size: 33.5mm square.

Part no.	Description
22-2000-X	Pushbutton
22-2000-X-AT	Pushbutton advanced technology
22-2002-X	Lens cap
22-2003-X	Legend plate



Round Small Button

Size: $\varnothing 31\text{mm}$ round.

Part no.	Description
22-2060-X	Pushbutton
22-2060-X-AT	Pushbutton advanced technology
22-2062-X	Lens cap
22-2063-X	Legend plate



Square Large Button

Size: 51mm square.

Part no.	Description
22-2010-X	Pushbutton
22-2010-X-AT	Pushbutton advanced technology
22-2012-X	Lens cap
22-2013-X	Legend plate



Round Medium Button

Size: $\varnothing 44\text{mm}$ round.

Part no.	Description
22-2070-X	Pushbutton
22-2070-X-AT	Pushbutton advanced technology
22-2072-X	Lens cap
22-2073-X	Legend plate

Advanced technology (AT)



- Completely compatible with all styles of Starpoint Pushbuttons.
- Single IDC Connector replaces 4 spade terminals.
- Optional diodes incorporated in the connector allows lamp and microswitch matrixing.

The Starpoint "AT" Formula

75% fewer connections with the unique "AT" connector.

- Easy fit.
 - Right first time connection.
 - Lower Assembly Costs.
- +
- One shot connection for fewer terminations.
 - Reduced wiring.
 - Reduced manufacturing time.



Rectangular Button

Size: 51 x 33mm rectangular.

Part no.	Description
22-2030-X	Pushbutton
22-2030-X-AT	Pushbutton advanced technology
22-2032-X	Lens cap
22-2033-X	Legend plate



Round Large Button

Size: $\varnothing 63.5\text{mm}$ round.

Part no.	Description
22-2080-X	Pushbutton
22-2080-X-AT	Pushbutton advanced technology
22-2082-X	Lens cap
22-2083-X	Legend plate

Advanced Technology Connector Options Table

Code	Microswitch Type	Microswitch Diode fitted	Lamp Diode fitted	Body colour	Part no.
A	2 Way	No	No	Yellow	22-2158-4
B	2 Way	No	Yes	Beige	22-2158-1
C	2 Way	Yes	Yes	White	22-2158-9
D					
E					
F					
G	3 Way Contact	No	No	Grey	22-2158-8
H	3 Way Contact	No	Yes	Red	22-2158-2
J	3 Way Contact	Yes	Yes	Black	22-2158



SAIA Microswitch

For Advanced Technology Buttons

Type: XCF8 - 30 gram.

Part no.	Description
22-0760-8	30 gram force switch

Pushbuttons



ILLUMINATED PUSHBUTTONS

- High quality materials.
- Microswitch included.
- Standard without lamp and/or artwork.
- Inscription labels available.
- Accommodate standard 10mm wedge base lamps.
- Sizes include black bezel.
- Fitting hole ø24mm.

All pushbuttons are available in the following colours:

Colour	Part no.
Red	2
Orange	3
Yellow	4
Green	5
Blue	6
White	9



Square Small Button

Size: 35mm square.

Part no.	Description
22-0600-X	Pushbutton
22-0602-X	Lens cap
22-0603-X	Legend plate



Square Large Button

Size: 50.5mm square.

Part no.	Description
22-0610-X	Pushbutton
22-0612-X	Lens cap
22-0613-X	Legend plate



Rectangular Button

Size: 51x33.5mm rectangular.

Part no.	Description
22-0630-X	Pushbutton
22-0632-X	Lens cap
22-0633-X	Legend plate



Round Small Button

Size: ø32mm round.

Part no.	Description
22-0660-X	Pushbutton
22-0662-X	Lens cap
22-0663-X	Legend plate



Round Medium Button

Size: ø44.5mm round.

Part no.	Description
22-0670-X	Pushbutton
22-0672-X	Lens cap
22-0673-X	Legend plate



Round Large Button

Size: ø61mm round.

Part no.	Description
22-0680-X	Pushbutton
22-0682-X	Lens cap
22-0683-X	Legend plate

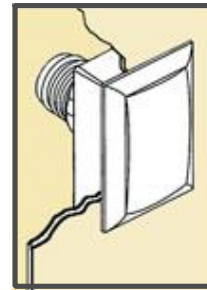

Low Profile
Illuminated
Pushbuttons



Square Button Small

Size: 38x38mm square.

Part no.	Description
22-0605-X	Low profile button



Square Button Large

Size: 52x52mm square.

Part no.	Description
22-0615-X	Low profile button



Rectangular Button

Size: 52x35mm rectangular.

Part no.	Description
22-0635-X	Low profile button



Round Button Small

Size: ø36mm round.

Part no.	Description
22-0665-X	Low profile button

Pushbuttons



Subminiature Poker Buttons with Twist-lock Lampholder Mechanism

These illuminated pushbuttons are designed to retrofit most existing slot and poker machine mini buttons. Small size, low profile and standard supplied with additional spacer bezel for either in or on top of panel mounting. These buttons are provided with easy twist-lock mechanism for lampholder for easier service and repair.

Features:

- Twist-lock lampholder mechanism.
- Highest quality materials.
- Standard industry sizes.
- Used with 5mm T1-1/2 wedge base lamps or LED's.
- Lens cap made of clear polycarbonate.
- Available in 6 different colours.
- Custom legend plate lettering or film available.
- Available in 4 sizes.
- Standard supplied with Cherry 2.8mm (.110) terminals.

All pushbuttons are available in the following colours:

Colour	Part no.
Red	2
Orange	3
Yellow	4
Green	5
Blue	6
White	9



Mini Square Miniature Button

- Lens cap size: 18.2 x 18.2mm.

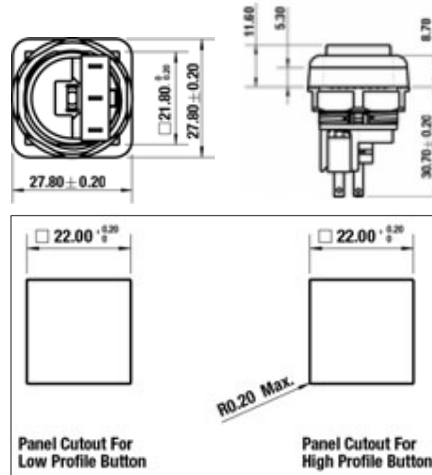

Part no.	Description
26-1140-X	Mini square miniature button
26-1142-X	Lens cap
26-1143-X	Legend plate



Rectangular Medium Miniature Button

- Lens cap size: 24.5 x 18.2mm.

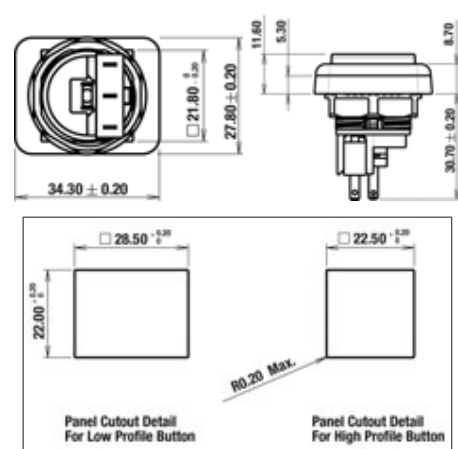

Part no.	Description
26-1150-X	Rectangular medium miniature button
26-1152-X	Lens cap
26-1153-X	Legend plate

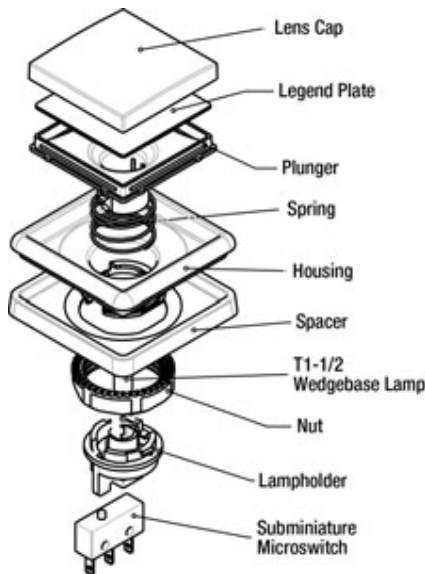

Microswitch for Subminiature Buttons

- With 2.8mm (.110) terminals.

Part no.	Description
22-0744-2	Microswitch Cherry



Rectangular Large Miniature Button

- Lens cap size: 36.7 x 18mm.

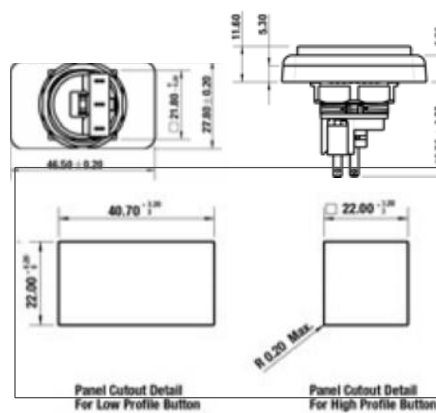

Part no.	Description
26-1130-X	Rectangular large miniature button
26-1132-X	Lens cap
26-1133-X	Legend plate



Large Square Miniature Button

- Lens cap size: 36.7 x 36.7mm.

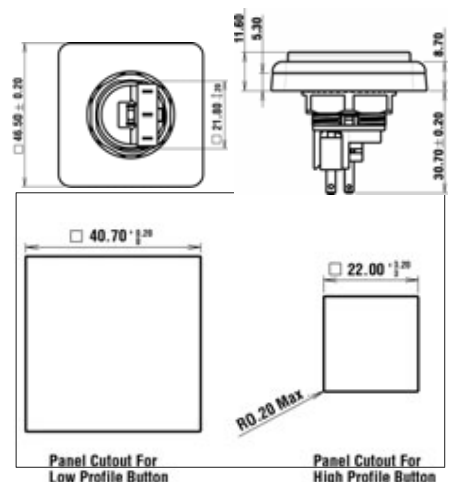

Part no.	Description
26-1160-X	Large square miniature button
26-1162-X	Lens cap
26-1163-X	Legend plate

Pushbuttons



ILLUMINATED PUSHBUTTONS



Part no.	Description
22-6010-X	Pushbutton



Part no.	Description
22-6030-X	Pushbutton



Lamp Holder

- Replacement lampholder for Gamesman pushbuttons.
- Supplied without microswitch or lamp.

Part no.	Description
22-1054	Lamp holder



Button Plugs for VLT Pushbuttons

- For use in metal control panels
- Fills in unused button holes
- Two sizes to choose from
- Comes with nut
- Fits in 22mm hole

Part no.	Description
H52-6209-00	Button plug, medium rectangle for VLT with nut
H52-6210-00	Button plug, rectangle for VLT with nut

Button with Illuminated Transparent Bezel



These buttons are without lamps, text or artwork printing.

Buttons available in 6 bright colours and including microswitch.

Lamp sockets accommodate standard 10mm wedge base lamp.

Now extra visual appeal with the new 1190 series transparent bezels.

The entire button surround comes to life, light being refracted and diffused throughout the body and the coloured bezel.

Gives an exciting dimension to the games.

Part no.	Description
22-1190-2	Red button
22-1190-4	Yellow button
22-1190-5	Green button
22-1190-6	Blue button
22-1190-9	White button



Jumbo Pushbutton

- Unique design, ideal for kiddie rides, etc.
- Available in red, yellow, green, blue and white.
- Outside diameter: 98mm!!
- Fitting hole \varnothing 24mm.
- Mounting depth: 65mm under panel.
- Supplied complete with microswitch.

Part no.	Description
22-0580-X	Jumbo pushbutton



Button Plug

- For use on wooden or metal control panels.
- Including nut. For 24mm hole.
- Fills in unused button holes.

Part no.	Description
22-1039	Button plug



Button Wrench

- Dual purpose.
- One end suitable for illuminated pushbuttons, other end for pushbuttons with microswitch.

Part no.	Description
22-1039-1	Button wrench



Pushbutton

Momentary contact pushbutton with screw mounting.

Part no.	Description
22-0055	Pushbutton



Miniature Momentary Contact Pushbutton

- Compact size to use in numerous applications.
- Momentary contact.

Part no.	Description
22-0729-1	Pushbutton switch



Microswitches for Pushbuttons

Part no.	Description
22-0731	Microswitch Saia
22-0731-2	Microswitch Cherry

Pushbuttons

www.leisureherrero.com



Pushbutton Assemblies

Super tough nylon and transparent plastic material.

Available in two lengths and six colours.

Light touch internal spring, short travel button. Short (41mm) buttons are used for mounting through metal and other materials approx 3.5mm thick.

Long (49mm) buttons are used for mounting through wood and other material approx 19mm thick.



Pushbutton Long model

- (49mm) for use in wood.

Part no.	Colour
22-1040	Black
22-1040-3	Orange
22-1040-5	Green



Pushbutton Small model

- (41mm) for use in metal panels.

Part no.	Description
22-1041-5	Green
22-1041-6	Blue



Full Transparent colours

Part no.	Colour
22-1040-13	Orange transparent
22-1040-15	Green transparent
22-1040-16	Blue transparent

Full Transparent colours

Part no.	Description
22-1041-12	Red transparent
22-1041-13	Orange transparent



Pal Nut

- 5/8" - 15.9mm zinc plated pal nut for use with all pushbutton assemblies.

Part no.	Description
1160-092	Pal nut



Pushbutton Holder

- Universal pushbutton holder with lamp mounting.

Part no.	Description
22-1050	Button holder



Leaf Switches

Can be used for many applications. All switches are made from the highest quality materials.

- With small silver contact points.

Part no.	Description
22-2201	Switch

- With heavy 4.5mm tungsten points.

Part no.	Description
22-2201-2	Switch



Button Holder Assy

- For metal panel.
- Complete with 22-2201-2 switch with heavy tungsten point switch.

Part no.	Description
22-1052-1	Holder assembly



Button Horizontal Microswitch

This video button has been developed for panels with economical space.

- Made from durable nylon, complete with nut and microswitch.
- Fits in wooden and metal panels.
- Available in: Black, Red, Orange, Yellow, Green, Blue and White.
- 1 or 2 player inscription.

Part no.	Description
22-2086-XX	Button (-X Specify colour)

Break Contacts

- With silver points.

Part no.	Description
22-2202	Switch

- With tungsten points.

Part no.	Description
22-2202-2	Switch

Handle Mechanisms

www.leisureherrero.com



Give your Slotmachine that competitive edge by fitting a handle mechanism!

The STC handle mechanism gives the appearance and feeling of a traditional slot machine.

Precisely engineered and built with selected materials.

Available in 3 different versions: (Standard - Premier - de Luxe) and 2 different mounting versions: 90° horizontal and 180° vertical.

(Accessories such as handle, hub, bolt and coverplate are not included).



Horizontal mounting



Vertical mounting

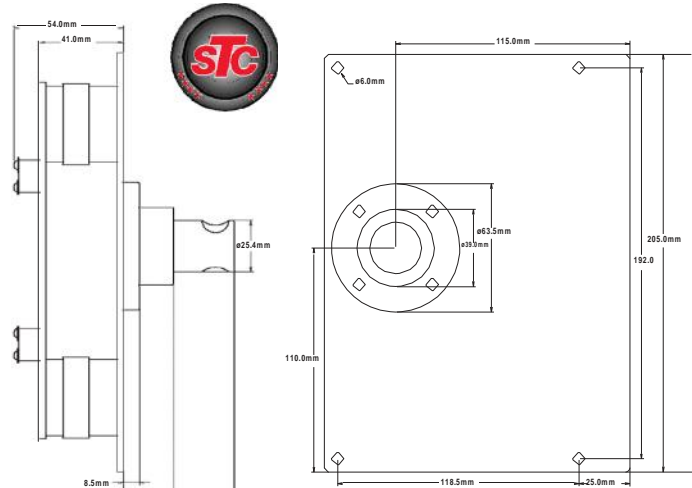

All sizes are metric in mm

Standard

Handle mechanism with start function only. Makes your machine like a real slot machine.

Part no.	Description
12-1800	Standard handle mechanism vertical
12-1900	Standard handle mechanism horizontal

-XX "Please give nos" -15=12VDC / -14=24VDC.

Premier

Handle mechanism with simulator gives the appearance and feeling of playing a real mechanical slot machine.

Part no.	Description
12-1810	Premier handle mechanism vertical
12-1910	Premier handle mechanism horizontal

Accessories like handle, hub, bolt and plate are not included.

De Luxe

Handle mechanism with simulator and handle lock. Gives the appearance and feeling of playing a mechanical slot machine. The handle lock offers the facility to block the mechanism when there are no credits.

Part no.	Description
12-1830-XX	De luxe handle mechanism vertical
12-1930-XX	De luxe handle mechanism horizontal



Hub

- Made from ABS material.
- Used with handle assy and cover plate.

Part no.	Description
12-1200-8	Hub chrome plated
12-1200-4	Hub gold plate



Hub

- Made from ABS material.
- Used with handle assy and cover plate.

Part no.	Description
12-1210-8	Hub chrome plated
12-1210-4	Hub gold plate



Mounting Bolt

Used for all STC handles.

Part no.	Description
678-101-700	Bolt



Handle Ball

- Standard available in black.
- Special colours available on request.
- Used for all STC handles.

Part no.	Description
12-1100	Black handle ball



Gray Code cam

Part no.	Description
12-1615	Standard cam



Cover Plate

- Made from ABS material.
- Used on the outside of your slot machine with hub.

Part no.	Description
12-1510-4	Cover plate gold
12-1510-8	Cover plate chrome



Handle Ball Assembly

These quality handles are finished with standard chrome finish.

Part no.	Description
12-1318	Long handle
12-1328	Short handle



One of the best contact blades in the world.

Save money !

Make switch assemblies yourself with the quick fit system



Insulating Fishpaper Blades

Part no.	Description
22-3072-55	55mm
22-3072-69	69mm



Brass Backing Blades

- Length: 24mm.

Part no.	Description
22-3071-24	Backing blade



Brass Switch Actuating Blades

- Length: 95mm / Width: 9.5mm.

Part no.	Description
22-3040	Actuating blade

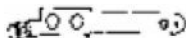

Standard Contact Blade with Cross Point

Part no.	Description
22-3020-30	Long blade



Universal Contact Blades with 7 Holes

Part no.	Description
22-3030-20	0.20mm
22-3030-25	0.25mm
22-3030-30	0.30mm
22-3030-40	0.40mm
22-3030-50	0.50mm



Targetblade

Part no.	Description
GA4345	Target blade



Steel Spring Blades

Part no.	Description
22-3070-41	41mm
22-3070-48	48mm
22-3070-55	55mm
22-3070-60	60mm
22-3070-67	67mm
22-3070-73	73mm
22-3070-79	79mm



Faston Side Lugs

Part no.	Description
22-3045	3/8" mounting



Quick-fit Switch Mounting Shafts

Part no.	Description
22-1047	Mounting shaft



Nylon Switch Actuators

Part no.	Description
22-3060	Switch actuator



Switch Fastening Plates

Part no.	Description
22-1048	Fastening plate

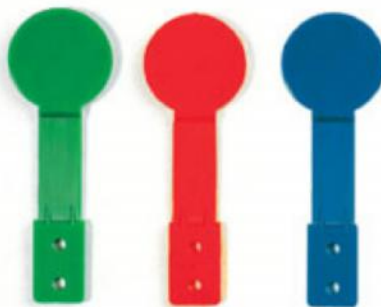

Target Actuator

One piece moulded target actuator.

Part no.	Description
BC1025-1	Round red
BC1025-2	Round blue
BC1025-4	Round green



Tungsten Contact Points

Part no.	Description
22-0177	4.5mm



Silver Contact Points with Gold Flashing

Part no.	Description
22-0063	Small oval
22-0063-1	Large oval



Plastic Insulating Separators

Part no.	Description
22-1049-16	1.6mm
22-1049-20	2mm
22-1049-24	2.4mm
22-1049-32	3.2mm



Plastic Switch Blade Lifters

Part no.	Description
GA5255	2.4mm
GA5256	3.2mm
GA5258	4.8mm
GA5259	5.6mm
GA5261	7.1mm